



ECON 600 H

Dust Collector System



Heavy duty hydraulically powered dust collector systems, designed for improved productivity and improved working conditions in the construction and mining industry.



ECON 600 Dust Collector System

The ILMEG ECON 600 H hydraulically driven dust collectors are used in rock drilling applications for improved productivity and improved working conditions with regards to dust. A typical application is blast hole drilling with top hammer rock drills.

The filter cleansing function is carried out with reversed air.

ILMEG dust collectors are continuously improved and built of high quality components to ensure long, safe and economical operation.

Specification:

Max hole size:	51 mm (2")
Filter area:	4,3 m ²
Oil flow requirement:	25 l/min
Oil pressure requirement:	100 BAR
Approx weight:	140 Kg
Filter cleansing system:	Reversed air
Electric system:	24 V

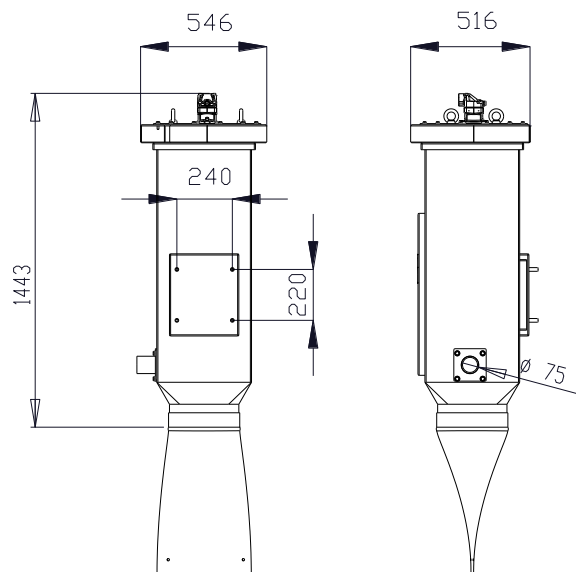

Optional Equipment:

- Pre-skimmer
- Pick-up hood



The heavy duty cuttings collector is specially designed to reduce the dust to the minimum.



The fan is purpose built with regards to the specific requirements in mobile drilling applications to ensure a high vacuum capacity in combination with a high suction flow capacity



The filter capacity is 4,3 m² with water resistant filter material in combination with the reversed air cleansing system safeguards a long and trouble free operation